

The CU Alarm is an audible alarm that sounds in the event the steam room maximum set temperature is exceeded or if the CU-SteamStop button has been pressed.

The CU Alarm may be mounted outside the steam room in a location that will alert an attendant and/or user to an over-temperature condition.

Review local codes for mounting location as required.



**⚠ WARNING** The CU Alarm shall not be mounted inside the steam room.

**⚠ WARNING** Please Read These Instructions Carefully Before Using this Product. The 115VAC CU Alarm must be field set to the desired dBA sound output level and alarm tone before installation. This is done by adjusting a four position switch in accordance with these instructions. Incorrect settings will result in improper performance.

dBA RATINGS		
Tone	dBA Reverberant at 10 feet	
	High	Standard
Horn	88	82
Bell	82	75
March Time Horn	85	79
*Code-3 Horn	85	75
*Code-3 Tone	79	75
Slow Whoop	88	82
Siren	85	82
Hi/Lo	82	79

\*See note on Page 3

**IMPORTANT NOTE:** As you follow these instructions, you will notice warning and caution symbols. This information is important for the safe and efficient installation and operation of this generator. These are types of potential hazards that may occur during this installation and operation:

**⚠ CAUTION** states a hazard may cause serious injury or death if precautions are not followed.

**⚠ WARNING** signals a situation where minor injury or product damage may occur if you do not follow instructions.

**! WARNING** MAKE SURE THAT ALL FUSES USED ON SIGNALING CIRCUITS ARE RATED TO HANDLE THE MAXIMUM INRUSH OR PEAK CURRENT FROM ALL APPLIANCES ON THOSE CIRCUITS. FAILURE TO DO THIS MAY RESULT IN LOSS OF POWER TO THE SIGNALING CIRCUIT AND THE FAILURE OF ALL APPLIANCES ON THAT CIRCUIT TO OPERATE.

The CU Alarm produce a brief inrush current that lasts for just 50 microseconds at a **peak value of 5.0 Amps**.

**! WARNING** IF 115VAC CU ALARMS ARE OPERATED WITHIN 15 INCHES OF A PERSON, THEY CAN PRODUCE A SOUND PRESSURE LEVEL THAT EXCEEDS THE MAXIMUM 120 dBA PERMITTED BY ADA AND OSHA RULES. EXPOSURE TO SUCH SOUND LEVELS CAN RESULT IN HEARING DAMAGE.

**SETTINGS:**

The Switch (SW1) of the CU Alarm, shown in Figure 1, is used to set the desired dBA sound output level and alarm tone. The factory settings are shown below. Read these instructions carefully before changing any of these factory settings.

**Figure 1: PC Board Layout Showing Location of Switch (Labeled SW1 on circuit board as shown)**

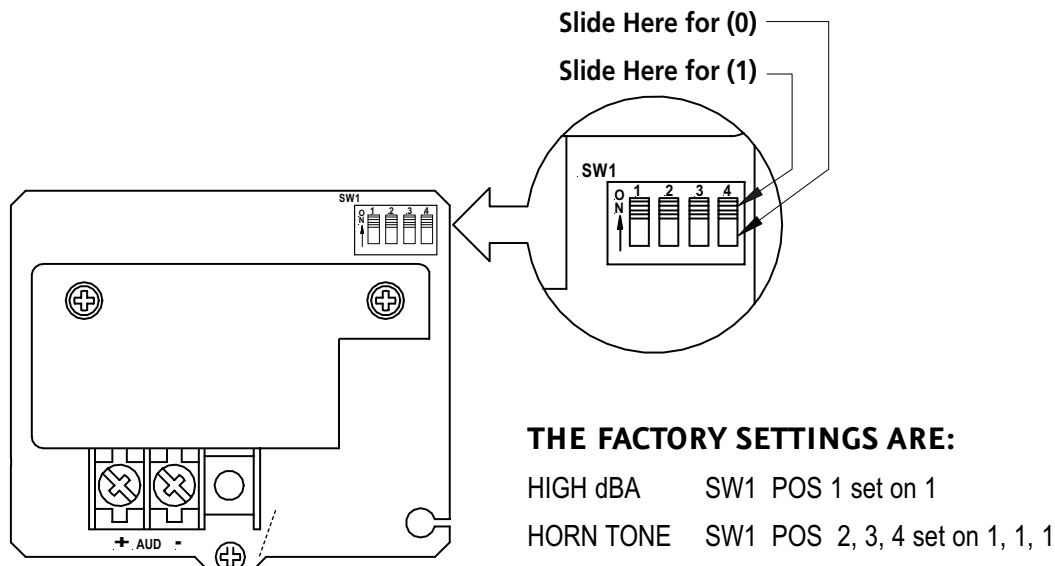

**STEP 1:**

Set desired dBA sound output by setting POS 1 of the four position switch (SW1). (refer to Figure 2 and Table 2).

**STEP 2:**

Set desired alarm tone by setting the four-position switch (SW1). Use POS 2, 3, 4 to select the desired alarm tone (refer to Table 3 below).

**Figure 2: SW1 Switch**

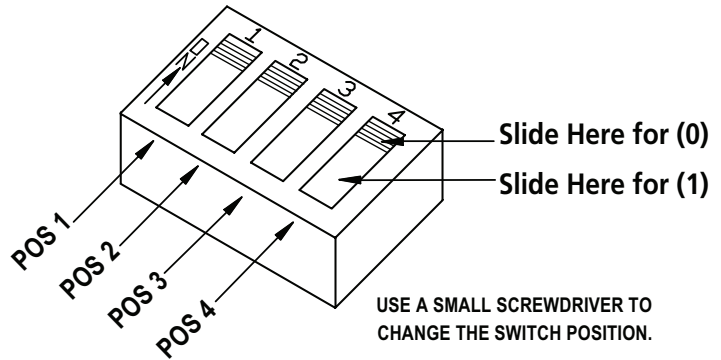

<b>TABLE 2 dBA Sound Output Level Settings</b>	
Decibel Level (dBA)	POS 1
High dBA	1 (Factory Setting)
Standard dBA	0

<b>TABLE 3 Alarm Tones</b>				
<b>Tone</b>	<b>Pattern Description</b>	<b>SWI Switch Settings</b>		
		<b>POS 2</b>	<b>POS 3</b>	<b>POS 4</b>
Horn	Broadband Horn (Continuous) (Factory Setting)	1	1	1
Bell	<b>1560</b> Hz Modulated ( <b>0.07</b> Sec. ON/Repeat)	<b>1</b>	<b>0</b>	<b>1</b>
March Time Horn	Horn ( <b>0.25</b> Sec.ON/ <b>0.25</b> Sec. OFF/Repeat)	<b>0</b>	<b>0</b>	<b>1</b>
* Code-3 Horn	Horn (ANSI S3.41 Temporal Pattern)	<b>1</b>	<b>1</b>	<b>0</b>
* Code-3 Tone	<b>500</b> Hz (ANSI S3.41 Temporal Pattern)	<b>0</b>	<b>1</b>	<b>1</b>
Slow Whoop	<b>500-1200</b> Hz Sweep ( <b>4.0</b> Sec. ON/ <b>0.5</b> Sec. OFF/Repeat)	<b>0</b>	<b>1</b>	<b>0</b>
Siren	<b>600-1200</b> Hz Sweep ( <b>1.0</b> Sec. ON/Repeat)	<b>1</b>	<b>0</b>	<b>0</b>
HI/LO	<b>1000/800</b> Hz ( <b>0.25</b> Sec. ON/Alternate)	<b>0</b>	<b>0</b>	<b>0</b>

\* **NOTE:** The Code-3 Horn and Code-3 Tone (set on HIGH dBA) incorporate the temporal pattern specified by ANSI/NFPA for standard emergency evacuation signaling. **They should be used only for fire evacuation signaling and not for any other purpose.**

**WIRING THE ALARM TO A MR.STEAM CU COMMERCIAL STEAM GENERATOR:**

**! WARNING** SHUT OFF ALL POWER AT BREAKER BEFORE STARTING THE INSTALLATION. ELECTRIC SHOCK CAN CAUSE DEATH OR SERIOUS INJURY.

**IMPORTANT NOTE:** All electrical wiring is to be installed by a qualified, licensed electrician in accordance with National and local electrical codes.

1. Strip leads 3/8 inches and connect to screw terminals. 115VAC CU Alarms have in-out wiring terminals that accepts two #12 to #18 American Wire Gauge (AWG) wires at each screw terminal.

**Diagram: CU 360-4500 with 120 Volt Digital 1 Control:**

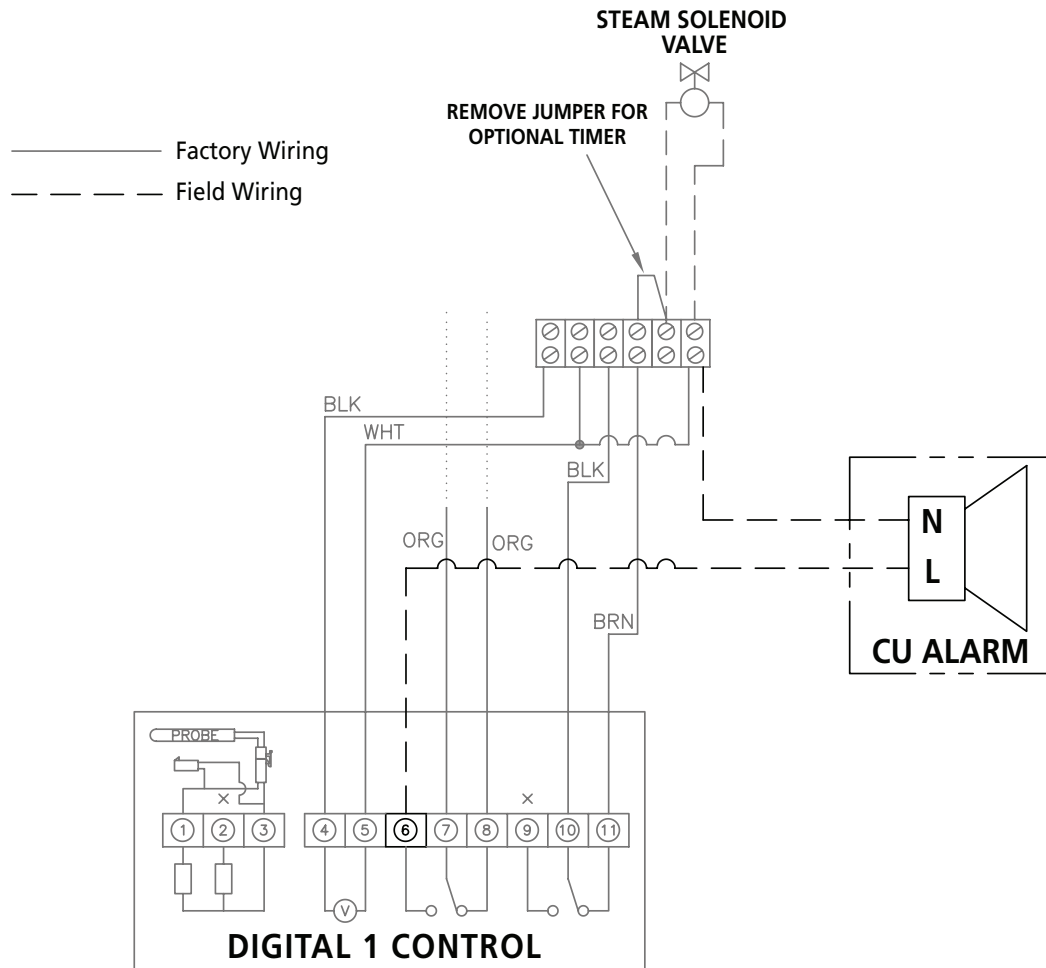

**NOTES:**

1. This Diagram shall only be used for wiring CU-Alarms. Consult the CU Installation Manual (PUR 100376) for complete boiler wiring information.
2. The Over Temperature Portion (Change Wires) of the D1 Temperature Controller must be connected for the CU-Alarm to operate correctly.

**Diagram: CU 360-4500 with 120 Volt F1 Plus Control:**

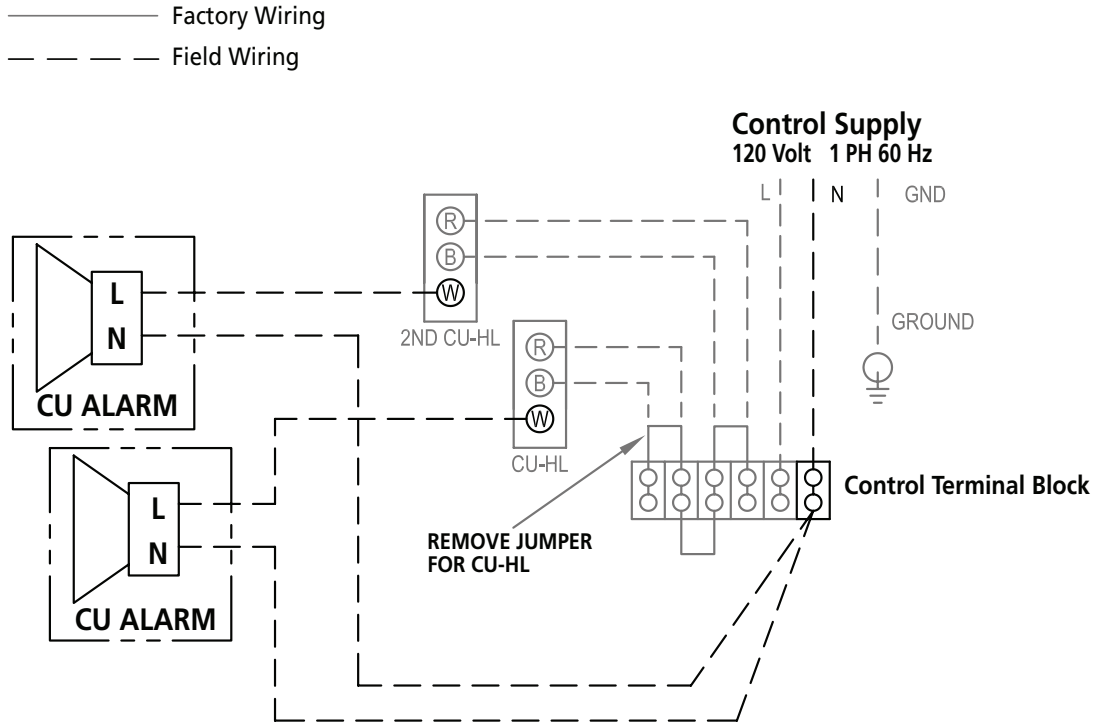

**NOTES:**

1. This Diagram shall only be used for wiring CU-Alarms. Consult the CU Installation Manual (PUR 100376) for complete boiler wiring information.
2. A CU-HL must be used in conjunction with each CU ALARM on boilers with F1 controls.

**SURFACE MOUNTING:**

**IMPORTANT NOTE:** All electrical wiring is to be installed by a qualified, licensed electrician in accordance with National and local electrical codes. Review local codes for mounting location as required.

**! WARNING** DO NOT mount the CU ALARM inside the steam room.

**! CAUTION** If sheathed multiconductor cable or 3/4" conduit fittings are used, check that installed CU Alarm has sufficient clearance and wiring room prior to installing electrical boxes and conduit.

1. 115 VAC CU ALARMS can be surface mounted to a standard 4 inch square by 2-1/8 inch deep electrical box (Figure A)
2. Select the largest electrical box possible (shown in Mounting Options) to provide the maximum wiring clearance for easy installation.
3. Conduit entrance to electrical boxes should be selected to insure sufficient wiring clearance for the CU Alarm. When extension rings are required, conduit should enter through electrical box, not extension ring.
4. Use care and proper techniques to position the field wires in the electrical box so that they use minimum space and produce minimum stress on the product. This is especially important for stiff, heavy gauge wires with thick insulation or sheathing.
5. Do not pass additional wires (used for other than signaling appliances) through the electrical box. Such additional wires could result in insufficient wiring space for the signaling appliance. The CU Alarm is designed to produce an audible alarm in the event the steam room maximum set temperature is exceeded.
6. Place the CU-ALARM identification label on or adjacent to the alarm.



**IMPORTANT NOTE:** The Code-3 Horn and Code-3 Tone incorporate the temporal pattern specified by NSI/NFPA/ISO for standard emergency evacuation signaling. They should be used only for fire evacuation signaling and not for any other purpose.

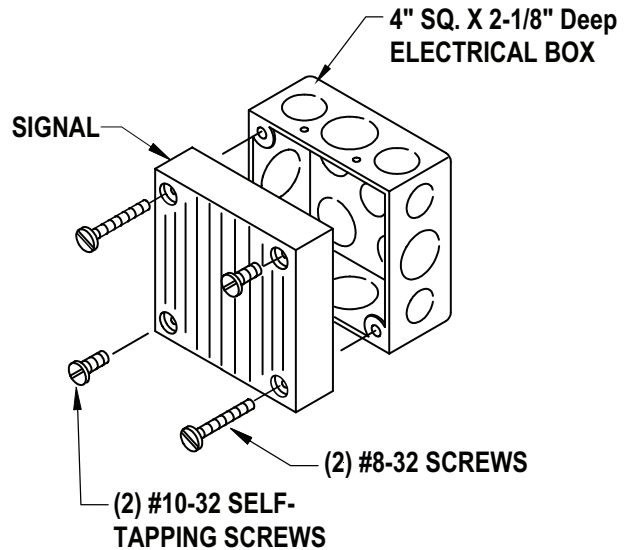

**OPERATIONAL CHECK:**

**WHEN USED WITH THE DIGITAL 1 CONTROL:**

1. Disconnect the probe wire connection at the back of the Digital 1 Control.
2. The boiler will shut off and the alarm will sound (the Digital 1 will read o o o).
3. If the alarm does not sound, disconnect power and swap the orange wires at terminal 7 & 8 on the back of the control.
4. Reconnect power and follow the operational check instructions.

**WHEN USING THE CU-STEAMSTOP:**

1. Press the CU-STEAMSTOP (the Digital 1 will read - - -)
2. The boiler will shut off and the alarm will sound.
3. If the alarm does not sound, disconnect power and swap the orange wires at terminal 7 & 8 on the back of the control. If the Digital 1 control does not display - - -, refer to the CU-STEAMSTOP Installation operation & Maintenance Manual.
4. Reconnect power and follow the operational check instructions.

**WHEN USED WITH THE F1 PLUS CONTROL AND CU-HL:**

1. Turn the CU-HL temperature dial down until the boiler turns off.
2. The alarm will sound. Reset the CU-HL set point.
3. If the alarm does not sound disconnect power and check wiring.